

VOLVO PENTA AQUAMATIC DUOPROP

D6-370/DPR

272 kW (370 hp) crankshaft power acc. to ISO 8665

NEW!

Exceptional diesel performance for high speed

Volvo Penta's 6-cylinder D6-370 is developed from the latest design in modern diesel technology. The engine has common rail fuel injection system, double overhead camshafts, 4 valves per cylinder, turbocharger, compressor, and aftercooler. The interaction of these, the large swept volume, and the EVC system results in exceptional diesel performance combined with low emissions. The D6-370/DPR is suitable for both single and twin engine installations in speeds above 47 knots.



D6-370 with DPR Duoprop drive

World-class performance

The common rail fuel injection system, controlled by EVC, and the compressor, in combination with a large swept volume, ensure unique torque over the whole speed range. The acceleration is very powerful, with virtually no sign of smoke. This matched with the engine's high load carrying capability creates a sporty feeling and power, when needed.

Compact and robust

The engine is lightweight and extremely compact for its large swept volume and high output. With the rear-end transmission, driving the high-pressure injection pump and the camshafts, a high degree of integrated systems, a high-efficiency aftercooler, a marinization performed with very few hoses, and a fully symmetric engine, the package simply gets that compact.

The rigid cast-iron cylinder block and head, ladder frame, and exactly controlled (up to three steps) fuel injection gives excellent onboard comfort with low noise and vibration levels.

EVC/EC- Plug and go

EVC Electronic Vessel Control is the latest development in engine control and instrumentation for Volvo Penta marine engines. It offers a higher level of integration in your boat: electronic shift and throttle for smooth and safe control, power trim control, a complete range of easy to read data link gauges, an EVC System Display (option) and much more, everything in just one CAN cable.

EVC makes boating easier and safer, offering twin engine and power trim synchronization and new software functions such as trip computer and power trim assistant. EVC is scalable from one station up to four, from a

classic dashboard up to an advanced driver information system.

EVC works closely together with the engine management system offering you constant power output regardless of temperature (5–55°C / 41–131°F) and quality of the fuel. The system is built on the latest automotive technology with waterproof connectors, so it's just plug and go.

High speed DPR drive

The corrosion-resistant aluminum high performance drive is based on the experience with the well-proven original DP drive, and fully matched to the very powerful engine.

The DPR drive is designed for speeds above 47 knots. The sporty styling, the hydrodynamic lower housing designed for extremely low drag, and the Duoprop stainless steel propellers, specially developed for the drive, make the package complete. This results in unbeatable DP characteristics in terms of acceleration, top speed and drivability. There is a unique constant and secure grip at high speeds, under all running conditions.

The drive comes equipped with fully hydraulic further developed X-act steering. It features integrated external steering cylinders, controlled by an exact feedback valve as standard.

The integrated exhaust system and seawater intake, a hallmark for Volvo Penta, are also standard.

Meeting new emission standards

The common rail injection system in combination with electronics and an advanced combustion system are setting new standards in minimizing noxious emissions and particulates. The engine complies with IMO NOx limits and the comprehensive emission requirements EU RCD and US EPA Tier 2.

The DPR drive has been designed to lead exhaust gases into the propeller path, to avoid the "station wagon effect" and keep noise levels at a minimum.

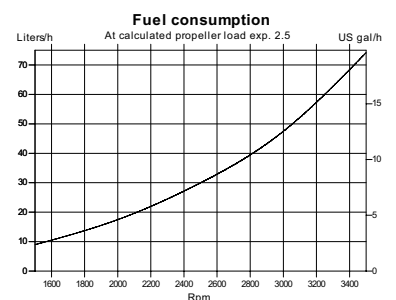
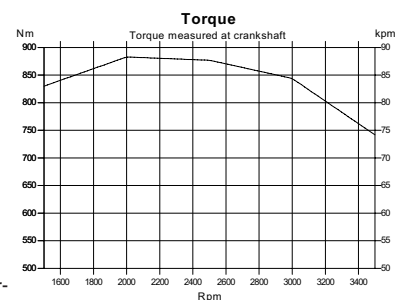
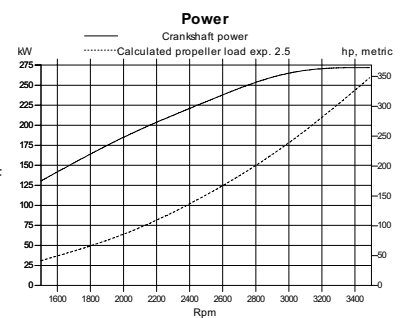

VOLVO PENTA

D6-370/DPR

Technical description:

Engine block and head

- Cylinder block and cylinder head made of cast-iron
- Ladder frame fitted to engine block
- 4-valve technology with hydraulic lash adjusters
- Double overhead camshafts
- Oil-cooled pistons with two compression rings and one oil scraper ring
- Integrated cylinder liners
- Replaceable valve seats
- Seven-bearing crankshaft
- Rear-end transmission

Engine mounting

- Flexible engine mounting

Lubrication system

- Easily replaceable separate full-flow and bypass oil filter
- Seawater-cooled tubular oil cooler

Fuel system

- Common rail fuel injection system
- Control unit for processing the injection
- Fine filter with water separator

Air inlet and exhaust system

- Belt-driven compressor with silencer of absorption type on both inlet and output port

- Air filter with replaceable insert
- Crankcase gases vented into the air inlet
- Exhaust elbow or exhaust riser
- Freshwater-cooled turbocharger

Cooling system

- Thermostatically regulated freshwater cooling
- Tubular heat exchanger with separate large volume expansion tank
- Coolant system prepared for hot water outlet
- Seawater strainer and easily accessible impeller pump

Electrical system

- 12V two-pole electrical system
- 115A marine alternator with Zener-diodes to protect the system from peak voltage, and integrated charging regulator with battery sensor cable for maximum use of alternator
- Fuses with automatic reset
- Auxiliary stop button

Instruments/control

- Complete instrumentation including key switch and interlocked alarm
- Digital Power Trim instrument with analog or digital reading
- EVC monitoring panels for single or twin installations
- Electronic remote control for throttle and shift
- Plug-in connectors

Drive

- Complete with transom shield, and installation components
- Max tilt angle 50° (adjustable)
- Protective zinc anodes to prevent corrosion
- Built-in kick-up function to reduce possible damage, in the event the drive strikes an underwater object
- Electrical shifting performed by electronic actuator
- Power Trim with one-button operation in twin installation
- Fully integrated water inlet and exhaust system
- Fully hydraulic power-assisted steering system
- Isolated propellers to prevent corrosion

Accessories

An extensive range of accessories are available. For detailed information, please see the Accessories & Maintenance Parts catalog (www.volvopenta.com).

Option

U.S.C.G./MED (SOLAS) kit available.

Contact your local Volvo Penta dealer for further information.

Not all models, standard equipment and accessories are available in all countries. All specifications are subject to change without notice.

The engine illustrated may not be entirely identical to production standard engines.

Technical Data

Engine designation	D6-370 A
Crankshaft power, kW (hp)	272 (370)
Propeller shaft power, kW (hp)	261 (355)
Engine speed, rpm	3500
Displacement, l (in ³)	5.5 (336)
Number of cylinders	6
Bore/stroke, mm (in.)	103/110 (4.06/4.33)
Compression ratio	17.5:1
Volvo Penta Duoprop drive	DPR
Ratio	1.36:1
Dry weight with DPR, incl. prop. & PS, kg (lb) ..	770 (1698)

Duty rating: R5

Technical data according to ISO 8665. With fuel having an LHV of 42,700 kJ/kg and density of 840 g/liter at 15°C (60°F). Merchant fuel may differ from this specification which will influence engine power output and fuel consumption.

The engine complies with IMO NOx and the comprehensive emission requirements US EPA Tier 2 and EU RCD.

Dimensions D6-370/DPR

Not for installation

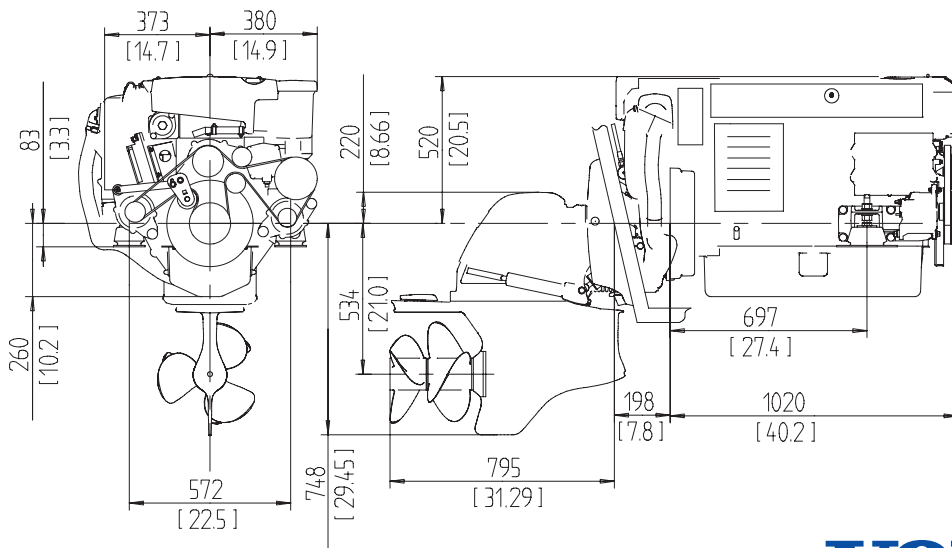

VOLVO PENTA

AB Volvo Penta

SE-405 08 Göteborg, Sweden
www.volvopenta.com